

BALL VALVE SPECIFICATION
(ボールバルブ仕様)

WORKING PRESSURE
使用圧力範囲 : 0~1.0MPa

SEAT LEAKAGE TEST AIR PRESSURE
弁座漏れ試験圧力 : 0.6MPa (空圧)

SHELL TEST WATER PRESSURE
本体耐圧試験圧力 : 1.5MPa (水圧)

TEMPERATURE RANGE
使用温度範囲 : -20~180°C

FINISH INSIDE BUFFING
仕上げ : 内面バフ研磨 (#320)

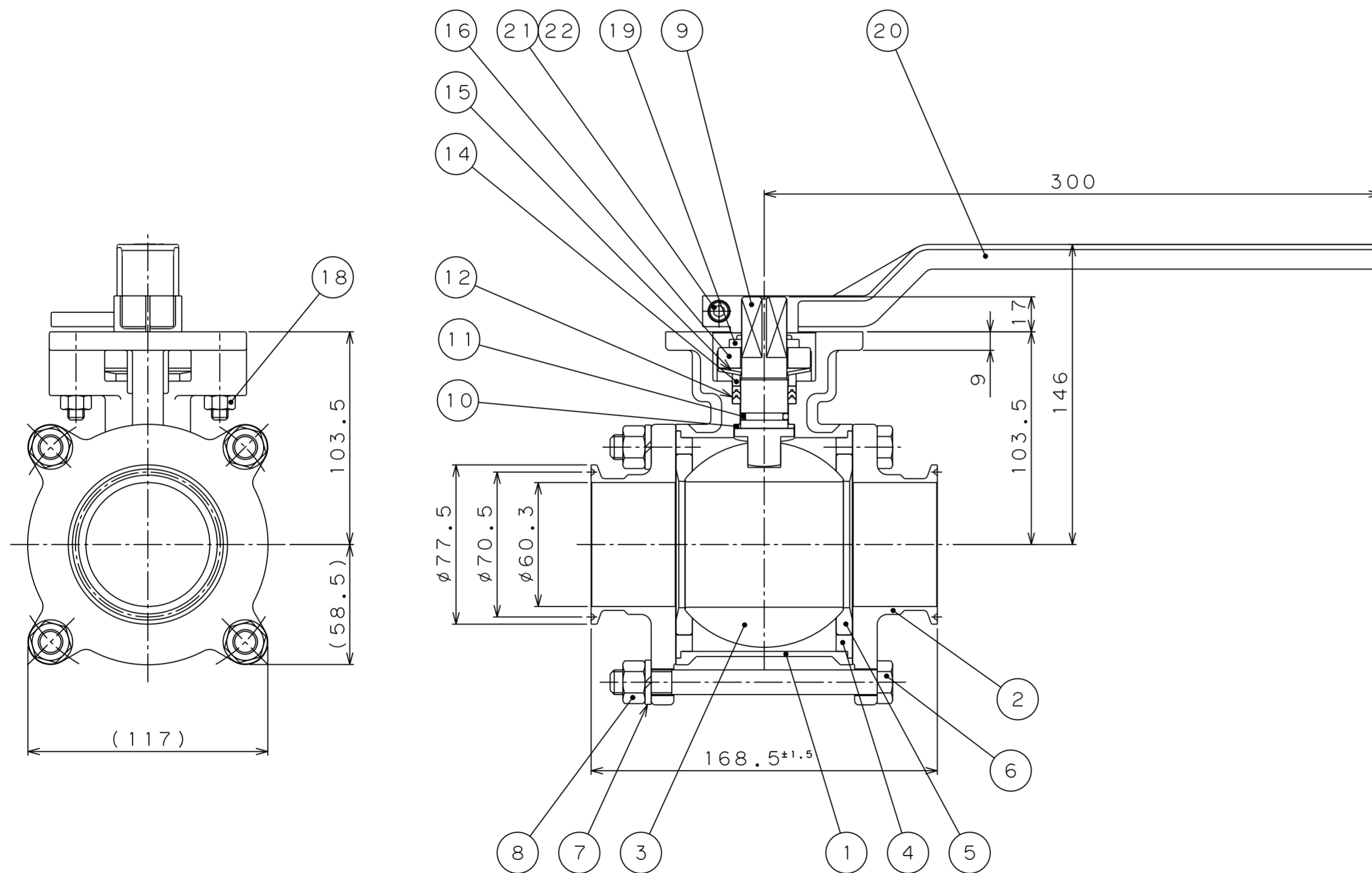

| | | | | | |
|----|------------|-----------------|---------|---|-------------------------|
| 22 | | NUT | A2-70 | 1 | M6 |
| 21 | | HEX SOCKET BOLT | A2-70 | 1 | M6-20L |
| 20 | A00AP-0130 | HANDLE | CF8 | 1 | SCS13A相当 EQUIVALENT |
| 19 | A65AP-2050 | STOPPER | 304 | 1 | SUS304相当 EQUIVALENT |
| 18 | | NUT | A2-70 | 2 | M8 SUS304相当 |
| 17 | | BOLT | A2-70 | 2 | M8-30L |
| 16 | A65AP-2040 | PACKING GLAND | CF8 | 1 | SCS13A相当 EQUIVALENT |
| 15 | A65AP-2120 | DISC SPRING | 304 | 1 | SUS304相当 EQUIVALENT |
| 14 | A65AP-2090 | GLAND | 304 | 1 | SUS304相当 EQUIVALENT |
| 13 | | | | | |
| 12 | A65AP-2080 | PACKING | TFM1600 | 1 | ダイキン M111 |
| 11 | A65AP-2130 | O-RING | FPM | 1 | |
| 10 | A65AP-2100 | STEM WASHER | PTFE | 1 | |
| 9 | A65AP-2030 | STEM | 316L | 1 | SUS316L相当 EQUIVALENT |
| 8 | | NUT | A2-70 | 4 | M12 |
| 7 | | SPRING WASHER | 304 | 4 | M12 SUS304相当 EQUIVALENT |
| 6 | | BOLT | A2-70 | 4 | M12-130L |
| 5 | A65AP-2071 | BALL SEAT | TFM1600 | 2 | |
| 4 | A65AP-2060 | GASKET | TFM1600 | 2 | |
| 3 | A65AP-2020 | BALL | CF3M | 1 | SCS16A相当 EQUIVALENT |
| 2 | A65AP-2010 | BONNET | CF3M | 2 | SCS16A相当 ISOヘルル |
| 1 | A65AP-2000 | BODY | CF3M | 1 | SCS16A相当 EQUIVALENT |

| ITEM NO. 符号 | PART NO. 部品番号 | TITLE 部品名称 | MATERIAL ETC. 材質など | No./OFF. 数/組 | DESCRIPTION (ORG. DWN. NO.) 摘要 (提携先図番) | | | | | | | | | | | | | | | | | | | | | | | | | | | | | | | | |
|---------------------|------------------|-----------------------------------|---|-----------------|---|----------|----|--|--|-------|-----|--|----|-----|----|--|--|-----|-----|--|----|----|--------|--|--|-----------|--|--|--|---------------------|--|--|--|----------|--|--|--|
| 削り加工寸法許容差 | | 特記事項: DESCRIPTION/O.N. ISO ヘルル | | MODEL 型式 | NCERES-HA-F-2.5S | | | | | | | | | | | | | | | | | | | | | | | | | | | | | | | | |
| 0.5以上 | 6以下 | 0.1 | <table border="1"> <tr><td>MATERIAL</td><td colspan="3">上記</td></tr> <tr><td>SCALE</td><td>1:2</td><td></td><td>A2</td></tr> <tr><td>材 質</td><td colspan="3">上記</td></tr> <tr><td>尺 度</td><td>1:2</td><td></td><td>A2</td></tr> <tr><td>図名</td><td colspan="3">HANDLE</td></tr> <tr><td colspan="4">2.5S ハンドル</td></tr> <tr><td colspan="4">BALL VALVE ASSEMBLY</td></tr> <tr><td colspan="4">ボールバルブ組立</td></tr> </table> | | | MATERIAL | 上記 | | | SCALE | 1:2 | | A2 | 材 質 | 上記 | | | 尺 度 | 1:2 | | A2 | 図名 | HANDLE | | | 2.5S ハンドル | | | | BALL VALVE ASSEMBLY | | | | ボールバルブ組立 | | | |
| MATERIAL | 上記 | | | | | | | | | | | | | | | | | | | | | | | | | | | | | | | | | | | | |
| SCALE | 1:2 | | | | | A2 | | | | | | | | | | | | | | | | | | | | | | | | | | | | | | | |
| 材 質 | 上記 | | | | | | | | | | | | | | | | | | | | | | | | | | | | | | | | | | | | |
| 尺 度 | 1:2 | | | | | A2 | | | | | | | | | | | | | | | | | | | | | | | | | | | | | | | |
| 図名 | HANDLE | | | | | | | | | | | | | | | | | | | | | | | | | | | | | | | | | | | | |
| 2.5S ハンドル | | | | | | | | | | | | | | | | | | | | | | | | | | | | | | | | | | | | | |
| BALL VALVE ASSEMBLY | | | | | | | | | | | | | | | | | | | | | | | | | | | | | | | | | | | | | |
| ボールバルブ組立 | | | | | | | | | | | | | | | | | | | | | | | | | | | | | | | | | | | | | |
| 6を超え | 30以下 | 0.2 | | | | | | | | | | | | | | | | | | | | | | | | | | | | | | | | | | | |
| 30を超え | 120以下 | 0.3 | | | | | | | | | | | | | | | | | | | | | | | | | | | | | | | | | | | |
| 120を超え | 315以下 | 0.5 | | | | | | | | | | | | | | | | | | | | | | | | | | | | | | | | | | | |
| 315を超え | 1,000以下 | 0.8 | | | | | | | | | | | | | | | | | | | | | | | | | | | | | | | | | | | |
| 1,000を超え | 2,000以下 | 1.2 | | | | | | | | | | | | | | | | | | | | | | | | | | | | | | | | | | | |
| その他許容差 | | 承認 APPD. | | 検図 REV. | | | | | | | | | | | | | | | | | | | | | | | | | | | | | | | | | |
| 角度 公差等級(中級) | 10' | 森 | 渡邊 | 製図 DWN. | 年月日 DATE | | | | | | | | | | | | | | | | | | | | | | | | | | | | | | | | |
| 表面粗さ | 3.2a | 森 | 渡邊 | 渡邊(政) | 2021.08.23 | | | | | | | | | | | | | | | | | | | | | | | | | | | | | | | | |
| 指示無きカド C0.2-0.3 | | 指示無きスミ R0.2-0.4 | | DRAWING NO. | | | | | | | | | | | | | | | | | | | | | | | | | | | | | | | | | |
| | | CERES CORPORATION | | 図番 | | | | | | | | | | | | | | | | | | | | | | | | | | | | | | | | | |
| | | | | A65AA-2040 | | | | | | | | | | | | | | | | | | | | | | | | | | | | | | | | | |

注記

記載内容は予告なく変更する場合があります。最新図面はご購入前にお問い合わせください。